

INSTALLATION INSTRUCTIONS – PRIMIAN-2™ S2C, S3C, S4C, S5C

Refer to website www.mackwell.com for specific data

Description

A conversion module for use only in emergency lighting applications consisting of a battery charger with short circuit protection, change-over circuit, dc/ac inverter and ballast hold-off circuit. Each module has basic insulation between the supply and battery circuit and incorporates deep discharge protection circuitry to protect the batteries.

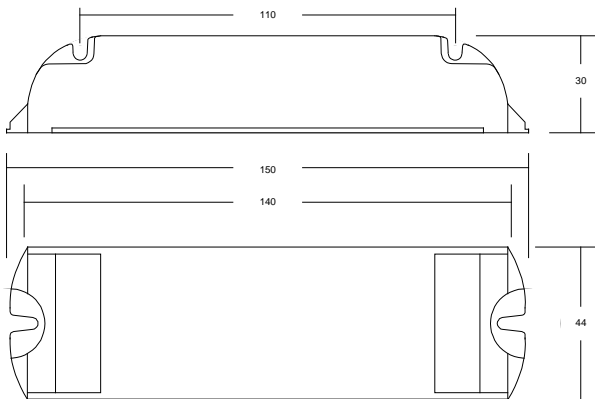

Specification

Supply Voltage	230Vac ± 10% 50/60 Hz
Supply Current	80mA max
Battery Charge current	90/210mA nominal
Ambient Temperature	0°C to +50°C
Max Case Temp	70°C
Conductor size	0.5 – 1.5mm ²
Mounting Screws	M4

Batteries

These modules are suitable for use with 4-4.5Ah rechargeable NiCd or NiMH cells for 3 hour operation (link in) or 1.5-1.6Ah NiCd or NiMH cells for 1 hour operation (link out).

Charge Indicator LED

A range of LEDs are available in red or green, diffused or clear high intensity, with or without a fitted rubber bezel or plastic clip and with various lead lengths.

Relevant Standards

EN 61347-2-7	Lamp control gear
EN 60598-2-22	Luminaire
ICEL 1004	Conversion to Emergency
BS5266-1:2005/IEC62034	Automatic testing

Important Conversion Notes.

Each conversion type must be backed up with a technical file showing that EMC, harmonics and temperature requirements are met. It should also include the layout of the conversion and wire routing.

Ensure that the finished converted luminaire operates within the module and battery temperature ratings.

Ensure that the original luminaire components are still operating within their temperature ratings.

Clearly identify the switched and unswitched mains terminations within the luminaire.

The polarity of the battery must be observed at all times. **Permanent damage to the module will occur if they are reversed.**

Before applying power to the luminaire, an insulation test must be carried out between the L & N connected together and Earth. **NOTE: The module connection marked Earth or Starting Aid should be disconnected for this test.**

Check the LED charge indicator is on with the unswitched supply present.

After a few minutes, remove the unswitched supply and ensure the lamp operates in emergency mode. If the luminaire is to be installed at a later date, disconnect the positive battery lead. **Do not reconnect until ready for commissioning, otherwise serious damage to the battery could occur.**

The luminaire must be identified with the company responsible for the conversion.

Mark the battery with the date of commissioning.

Typical Wiring Diagram

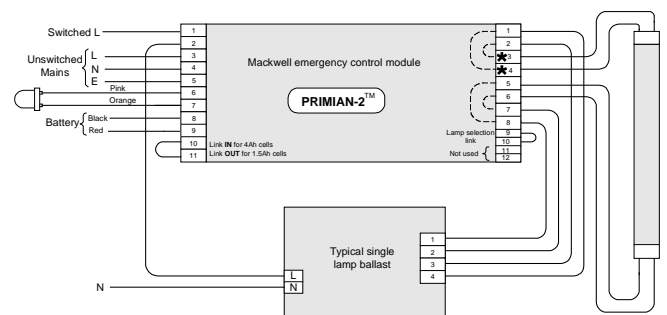

Important: It is strongly recommended that the lamp wires in the connections marked ★ do not exceed 500mm as lamp operation may be affected.

We can suggest other wiring diagrams for alternative mains gear, either see the website or contact our Technical Support Department. In all circumstances it is the responsibility of the Conversion Authority to ensure correct operation of the luminaire following a conversion for emergency use.

Warranty

All our electronic products are guaranteed for three years to cover faulty workmanship and materials. This "Return to Base" warranty requires that the product is used within the terms and conditions stated above and in our literature, and in particular, with the correct battery. Products returned to us under warranty must be carriage paid. Mackwell Electronics Ltd. accept no liability for costs incurred.

IMPORTANT

Please ensure that the information contained in this leaflet is passed on to the user/maintenance engineer.

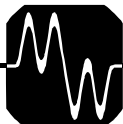

AutoTest®

If the product is fitted with AutoTest® (denoted by the prefix 'A'), the wiring changes as shown below.

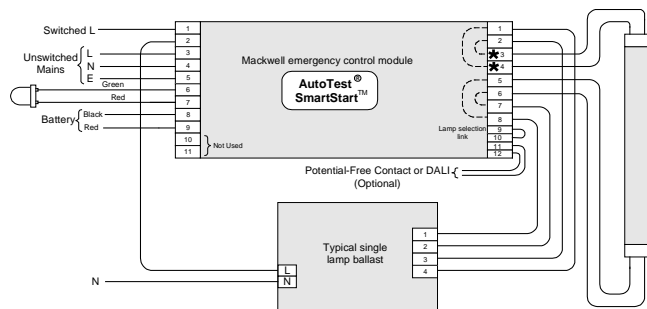

Operation

The module is capable of testing the performance of the emergency luminaire in accordance with BS5266-1:2005 and IEC62034.

Automatic Operation - Commissioning Test

Connection of the mains supply will initiate commissioning where the battery will remain on charge for an uninterrupted 24 hours. An interruption of the mains supply will reset the counter to zero. After 24 hours the luminaire will be put into a duration test for the rated period, immediately followed by another 24 hour charge period.

If the mains supply is to be interrupted for more than 7 days, then the battery MUST be disconnected.

Functional Test

A 30 second functional test is carried out at 30 day intervals. This test can also be initiated manually by switching the permanent supply OFF/ON twice within 5 seconds.

Duration Test

A full rated duration test is carried out automatically at yearly intervals.

Note that start times of the tests are set automatically to ensure random testing of the units.

LED Indicator

A bi-colour LED indicates the status of the module as follows:

Green	10 second 'blink'	Normal standby mode
	Slow flash	Commissioning mode or Duration Test in progress
	Fast flash	Functional Test in progress
Red	Slow flash	Charging or battery fault
	Fast flash	Lamp fault

Slow flash = 0.5Hz, fast flash = 2.5Hz

Audible alarm

An audible alarm will sound if a fault is found during test and will continue to give 3 beeps every 35 minutes until the fault is rectified and the unit is reset.

User Reset Facility

A recorded fault condition may be cleared by switching either the permanent or switched supply OFF/ON twice within 5 seconds. A Functional Test is then carried out automatically to verify correct system operation.

Potential-Free Contact Option (/P suffix)

NC (normally closed) terminals are provided for connection to a remote monitoring system (contacts open in the event of an alarm).

Contact Rating 24V ac or dc, 20mA
Max ON resistance 3 ohms

DALI Communications Option (/D suffix)

This allows two wire communication between the module and a central monitoring or control system designed to meet the requirements of draft DALI standard IEC 62386. For a full explanation see "Mackwell Emergency Modules with DALI Interface – Description and Operating Notes", part number 39795.

Important Note

The NC terminals are not SELV rated and must not be connected to SELV circuits. Wiring to the NC terminals must be in accordance with mains wiring and isolation requirements.